

AES RACKMOUNT

Energy Storage System

AES RACKMOUNT Battery Module Combiner (No Breaker) User Manual

READ AND SAVE THESE INSTRUCTIONS

Battery Module Combiner 950-0049-NB

- INTRODUCTION 3
- 1. AUDIENCE, MESSAGES, WARNINGS, GENERAL SAFETY, PERSONAL PROTECTIVE EQUIPMENT 3
 - 1.1 Audience 3
 - 1.2 Warning, Caution, Notice, and Note Messages 3
 - 1.3 Warnings and General Safety 4
 - 1.4 Safe Handling Procedures 4
 - 1.5 Personal Protective Equipment 5
- 2. ITEMS SHIPPED IN THE BOX 5
- 3. SPECIFICATIONS 6
 - 3.1 Electrical Specifications 6
 - 3.2 Mechanical Specifications 6
- 4. HANDLING 8
- 5. FEATURES 8
- 6. THEORY OF OPERATION 9
 - 6.1 Ingress Protection IP20 9
 - 6.2 LYNK Network Communication 9
 - 6.3 Remote Power ON/OFF Key Operation 11
 - 6.4 At-a-glance LED Status 11
- 7. PREPARING THE BATTERY MODULE COMBINER (NB) FOR INSTALLATION 12
 - 7.1 Tools 12
 - 7.2 Terminal Connections 12
 - 7.3 Removing Unused Battery Module Cables 13
 - 7.4 Installing Cables for the Power Conversion System 14
- 8. MOUNTING THE BATTERY MODULE COMBINER (NB) 16
 - 8.1 Location 17
 - 8.2 Spacing 17
 - 8.3 Support 18
- 9. CONNECTING THE BATTERY MODULE COMBINER (NB) 19
 - 9.1 Grounding the Battery Module Combiner (NB) 19
 - 9.2 Connecting the Battery Modules 20
 - 9.3 Connecting the DC Power Conversion Cables 20
 - 9.4 Networking the Battery Modules to the Battery Combiner Module 21
- 10. CLOSED-LOOP COMMUNICATION WITH POWER CONVERSION EQUIPMENT ... 21
- 11. ROUTINE INSPECTION 21
- 12. REPLACING A FUSE 22
- 13. OPTIONAL ACCESSORIES 23
- 14. RELATED INFORMATION 23

INTRODUCTION

The AES RACKMOUNT Battery Module Combiner (No Breaker) is designed for use with AES RACKMOUNT Battery Modules to connect in parallel up to six AES RACKMOUNT Battery Modules. The Battery Module Combiner (NB) comes equipped with six sets of cables for connection with AES RACKMOUNT Battery Modules. Two (unpopulated) DC Fuse positions are available for DC loads.

1. AUDIENCE, MESSAGES, WARNINGS, GENERAL SAFETY, PERSONAL PROTECTIVE EQUIPMENT

1.1 Audience

Configuration, installation, service, and operating tasks should only be performed by qualified personnel in consultation with local authorities having jurisdiction and authorized dealers. Qualified personnel should have training, knowledge, and experience in the:

- Installation of electrical equipment
- Application of electrical codes, safety, and installation standards
- Analysis and reduction of hazards involved in performing electrical work
- Installation and configuration of batteries

1.2 Warning, Caution, Notice, and Note Messages

Messages labeled on the Battery Module Combiner (NB) and in this manual are formatted according to this structure.



Additional information concerning important procedures and features of the Battery Module Combiner (NB). Read all the instructions before installation, operation, and maintenance.



Important information regarding hazardous conditions.

WARNING

Important information regarding hazardous conditions that may result in personal injury or death.

CAUTION

Important information regarding hazardous conditions that may result in personal injury.

NOTICE

Important information regarding conditions that may damage the equipment but not result in personal injury.

NOTE

Ad hoc information concerning important procedures and features unrelated to personal injury or equipment damage.

1.3 Warnings and General Safety



Do not dispose of the product in a fire or the garbage.



This product is made of recyclable materials and should be recycled.



⚠ WARNING

ELECTRIC SHOCK AND FIRE HAZARD

Do not lay tools or other metal parts across battery terminals or internal components.

Failure to follow these instructions may result in death or serious injury.

⚠ CAUTION

ELECTRIC SHOCK HAZARD

- Do not touch the energized surfaces of any electrical component in the Battery Module Combiner (NB) or Battery Module system.
- Before servicing, follow all procedures to fully de-energize the Battery Module Combiner (NB) and Battery Module system.
- Follow "Safe Handling Procedures" when working with the Battery Module Combiner (NB) or Battery Module system.

Failure to follow these instructions may result in injury.

1.4 Safe Handling Procedures

Before using the Battery Module Combiner (NB) with Battery Modules, read all instructions and cautionary markings on the units and all appropriate sections of this manual.

- Use personal protective equipment when working with the Battery Module Combiner (NB).
- Dispose of or recycle a Battery Module Combiner (NB) following local regulations.
- Do not modify, re-manufacture, or attempt to insert foreign objects into the Battery Module Combiner (NB).

- Do not immerse or expose the Battery Module Combiner (NB) to water, other liquids, fire, explosion, or other hazards.
- Only use the Battery Module Combiner (NB) with AES RACKMOUNT Battery Modules or with batteries that Discover Energy Systems specifies as compatible.
- Do not lift or carry while in operation.
- Take precautions when handling electrical cables.
- Do not submerge the Battery Module Combiner (NB).
- Do not install the Battery Module Combiner (NB) with the faceplate down.
- Do not use the Battery Module Combiner (NB) with Battery Modules or a Power Conversion system that exceeds the specifications of the Battery Module Combiner (NB). Using Battery Modules or a Power Conversion system that exceeds the cable and fuse specifications may present a fire risk or other hazards.
- Do not short-circuit the Battery Module Combiner (NB) or allow metallic conductive objects to contact cable ends and terminals.
- Do not drop the Battery Module Combiner (NB).
- If the Battery Module Combiner (NB) is damaged, take it to a service center for inspection.

1.5 Personal Protective Equipment

When handling or working near a battery:

- Use Personal Protective Equipment, including clothing, glasses, insulated gloves, and boots.
- Do not wear rings, watches, bracelets, or necklaces when handling or working near the battery.

2. ITEMS SHIPPED IN THE BOX

Table 2-1, AES RACKMOUNT Battery Module Combiner (No Breaker) contents

| ITEMS | DESCRIPTION |
|---------|--|
| 1 | AES RACKMOUNT Battery Module Combiner (No Breaker) |
| 6 Pairs | Positive (Red) and Negative (Black) Battery Module Cables with Amphenol SurLok Plus™ Connectors |
| 1 | CAT6 Cable (304.8 mm, 12 inch) |
| 24 | Cable Strap (304.8 mm, 12 inch) |
| 4 | Mounting Screw (M6) |
| 4 | Power Conversion Equipment Terminal Screws (M8) |
| 1 | #6 Chassis Ground Wire (200 mm, 7.87 inch) |
| 4 | Cage Nut (M5) |
| 1 Set | Spares: Cover Screws M3 (2) and M4 (2), Mounting Screws M6 (2), Cage Nuts (M5) 2, Cable Straps (304.8 mm, 12 inch) 2 |

3. SPECIFICATIONS

3.1 Electrical Specifications

The AES RACKMOUNT Battery Module Combiner (No Breaker) is designed for use with AES RACKMOUNT Battery Modules.

Table 3-1. AES RACKMOUNT Battery Module Combiner (No Breaker) Electrical Specifications

| Electrical Specifications | AES RACKMOUNT Battery Module Combiner (No Breaker) 950-0049-NB |
|------------------------------------|---|
| DC Battery Voltage Max | 60 V |
| DC Battery Current Max | 500 A |
| DC Power Conversion Voltage Max | 60 V |
| DC Power Conversion Current Max | 500 A |
| DC Fuses for Battery Module Cables | 6 x 100 A, Fast 20 kAIC For instructions, refer to 12. REPLACING A FUSE. |

3.2 Mechanical Specifications

Table 3-2. AES RACKMOUNT Battery Module Combiner (No Breaker) Mechanical Specifications

| Mechanical Specifications | AES RACKMOUNT Battery Module Combiner (No Breaker) 950-0049-NB |
|--|--|
| Height | 89.0 mm (3.5 inch) |
| Body Width | 440 mm (17.32 inch) |
| Body Width (with side flange) | 482.6 mm (19.0 inch) |
| Depth | 459.7 mm (18.1 inch) |
| Weight | 6.6 kg (18.52 lbs) 15.6 kg (38.36 lbs) with battery cables |
| Large Knockout: Power Conversion Cables | 2 x 2.47 inch (62.7 mm) |
| Medium Knockout: Battery Module Cables | 8 x 1.18 inch (30 mm) |
| Small Knockout: (Optional use) | 2 x 0.87 inch (22 mm) |
| Positive Terminals: Power Conversion Cables ⁽¹⁾ | 2 x M8 (8 mm, 0.315 in). Head: 13 mm (approx. 0.51 in) |
| Negative Terminals: Power Conversion Cables ⁽¹⁾ | 2 x M8 (8 mm, 0.315 in). Head: 13 mm (approx. 0.51 in) |
| Positive Terminals: Battery Module Cables ⁽²⁾ | 8 x M6 (6.0 mm, 0.236 inch). Head: 10 mm (approx. 0.39 in) |

| Mechanical Specifications | AES RACKMOUNT Battery Module Combiner (No Breaker) 950-0049-NB |
|--|--|
| Negative Terminals: Battery Module Cables ⁽²⁾ | 8 x M6 (6.0 mm, 0.236 inch) Head: 10 mm (approx. 0.39 in) |
| Battery Module Cables | 6 pairs, 3 AWG (26.5 mm ²) |
| Case Material | Zinc plated steel |
| IP Rating | IP20 |

(1) For the Power Conversion terminals, configure DC fuses and DC cables to match the requirements of the Power Conversion Equipment (inverter-charger / MPPT controller).

(2) Six positive terminals for Battery Modules are populated with DC fuses and DC battery cables. The remaining two positive terminals are open and available. Correspondingly, six negative terminals for Battery Modules are populated with DC battery cables and the remaining two negative terminals are open and available.

3.2.1 Dimensions

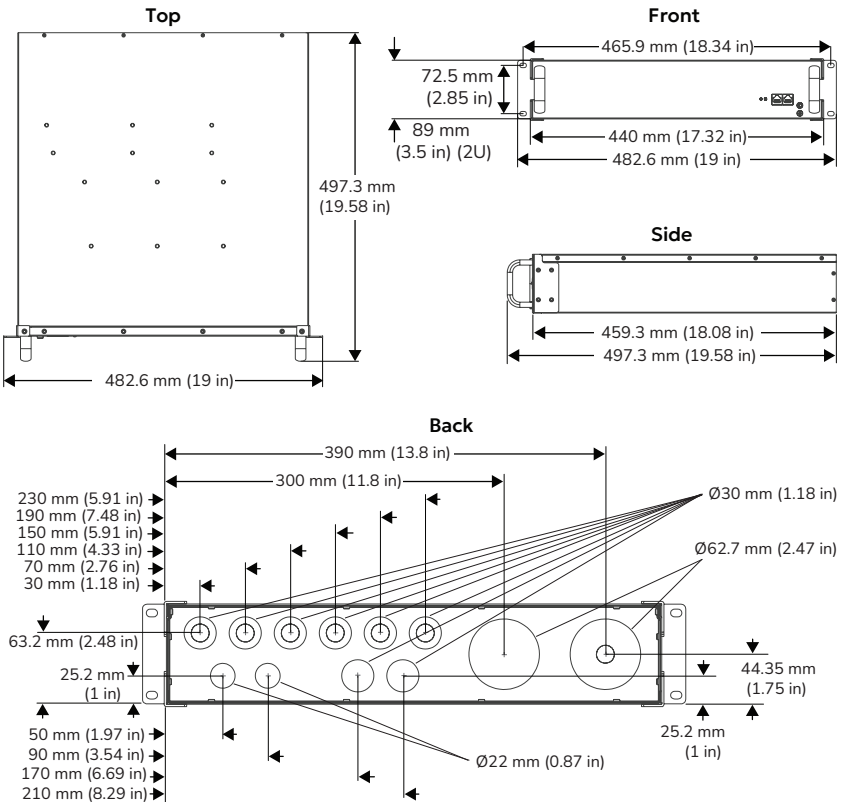

Figure 1. Battery Module Combiner (NB) Dimensional Drawings

NOTICE

Install cable strain relief to protect cables from wear. Follow local codes and standards for cables passed through knockouts.

4. HANDLING

Before handling

- Keep the Battery Module Combiner (NB) away from water, heat, and fire.
- Disconnect all cables from Battery Modules, inverter-chargers, MPPT controllers, and other power sources.
- Protect Battery Module Combiner (NB) terminals from short-circuiting and touch.
- Do not lift or carry the Battery Module Combiner (NB) while in use or operation.
- Do not lift or carry the Battery Module Combiner (NB) by the attached cables.

5. FEATURES

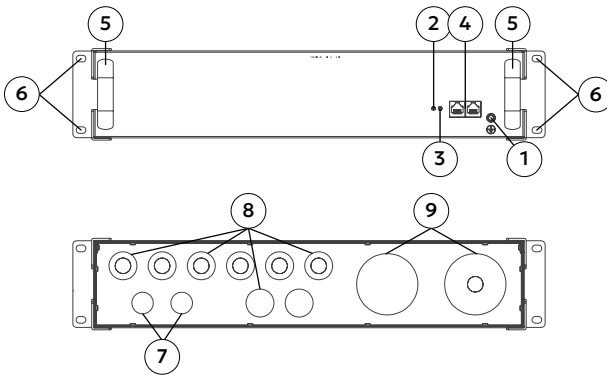

Figure 2. Battery Module Combiner (NB) (front, back)

| Item | Description |
|------|--|
| 1 | Equipment Ground Point |
| 2 | At-a-glance LED |
| 3 | Remote Power Off Key |
| 4 | LYNK Port x 2 |
| 5 | Handles x 2 |
| 6 | Mounting Points x 4 |
| 7 | Small Knockouts: 2 x 0.87 inch (22 mm) (Optional use) |
| 8 | Medium Knockouts: 8 x 1.18 inch (30 mm) (Battery Module Cables) |
| 9 | Large Knockouts: 2 x 2.47 inch (62.7 mm) (Power Electronic Cables) |

6. THEORY OF OPERATION

The no-breaker model of the Battery Module Combiner has no built-in breaker. Depending on the local authority having jurisdiction, you may be required to add external disconnects in the positive pole, or both negative and positive poles, to protect the Battery Modules' electronic components from high, externally generated currents.

The AES RACKMOUNT Battery Module Combiner (No Breaker) features DC Fuses to protect the cables leading to the Battery Modules. Two (unpopulated) DC Fuse positions are available for an MPPT controller or DC loads.

A solid green LED indicates that one or more Battery Modules are switched ON. The LYNK Port networks the Battery Module Combiner (NB) with the Battery Modules and a LYNK Gateway device to enable closed-loop communication with Power Conversion Equipment. The Remote Power Off key inverts the state (ON/OFF) of the connected Battery Modules.

6.1 Ingress Protection IP20

Ingress protection rates the degree of protection provided by mechanical casings and electrical enclosures against intrusion, dust, accidental contact, and water under specified conditions. The IP20 rating indicates that the product is touch-proof and resistant to dust or objects larger than 12 mm (0.47 in). However, it has no protection against liquids, so it is susceptible to damage if it comes into contact with water sprays.

IP codes guide suitability for use under different environmental conditions. IP ratings do not indicate fitness for purpose or confer a performance guarantee.

6.2 LYNK Network Communication

The Battery Module Combiner (NB) has two LYNK Ports. One is used to network with the Battery Modules and enables the ON/OFF switching of multiple Battery Modules with a touch of the Remote Power Off key.

The second LYNK Port connects a LYNK II Gateway and enables the Battery Modules to engage in closed-loop communication with compatible Power Conversion systems. Refer to the 805-0033 [LYNK II Installation and Operation Manual](#) for the setup of LYNK II.

For instructions on the setup of closed-loop communication with Power Conversion Equipment, refer to the LYNK II application note specific to the brand of Power Conversion Equipment (inverter-charger / MPPT controller) used. Refer to discoverenergysys.com.

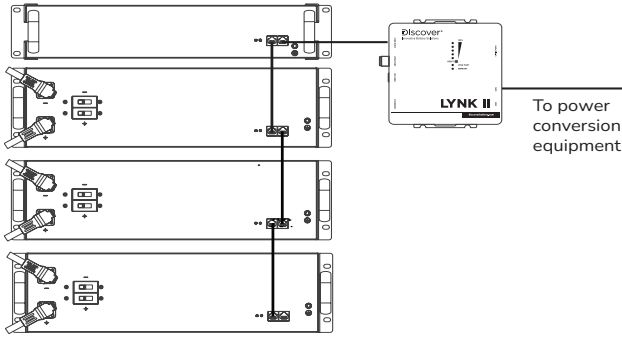
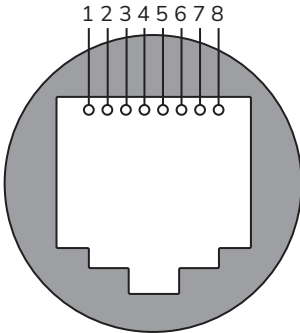

Figure 3. Battery Module Combiner (NB) connected to the Battery Module Network and a LYNK II Gateway

NOTE

- Connect the LYNK II communication gateway to the first or last device connected, whether it be a Battery Module or the Battery Module Combiner (NB).
- One LYNK Network can support up to 36 AES RACKMOUNT Battery Modules. The total length of the LYNK network cables must not exceed 36 m (118.11 ft).

6.2.1 LYNK Port RJ45 Pin Assignment



| Pin Number | Function |
|------------|-----------------------|
| 1 (1) | Reserved. Do not use. |
| 2 (1) | Reserved. Do not use. |
| 3 (1) | Reserved. Do not use. |
| 4 | CAN Low |
| 5 | CAN High |
| 6 (1) | Reserved. Do not use. |
| 7 | CAN Ground |
| 8 | CAN Ground |

Figure 4. LYNK Port Communication RJ45 pin assignment

⁽¹⁾ Do not populate. Do not terminate to power. Do not terminate to ground. Do not terminate to CAN_L or CAN_H.

NOTICE

- Use a straight-through cable. Do not use a cross-over cable.
- Isolate unused pins. Crossing pin functions may cause system damage.
- Do not terminate unused wires to ground, power, or other functions.
- Mixing the LYNK Network with other networks may result in equipment malfunction and damage.

6.3 Remote Power ON/OFF Key Operation

Briefly pressing the Battery Module Combiner's Remote Power ON/OFF key will invert the state of the connected Battery Modules.

The Remote Power ON/OFF Key on the Battery Module Combiner (NB) will function correctly when:

- The Battery Module Combiner's cables are connected to all the Battery Modules.
- The Battery Module Combiner (NB) is networked with all Battery Modules using the LYNK ports on each.

If the states of the Battery Modules are not synchronized, switch all the Battery Modules to OFF.

1. Press and hold the Remote Power Off Key for five or more seconds to trigger all the Battery Modules to switch ON.
2. Release the Remote Power Off Key, and all the Battery Modules are switched OFF.

The Remote Power Off key is now programmed to switch all Battery Modules to ON.

NOTICE

The Remote Power Off Key does not disconnect the Battery Modules from the Power Conversion system. Use external disconnects to disconnect the Battery Modules from the Power Conversion system.

6.4 At-a-glance LED Status

WARNING

ELECTRIC SHOCK AND FIRE HAZARD

- Always assume the Battery Module Combiner (NB) is energized, even if the At-a-glance LED shows that the Battery Modules are OFF.
- Even if the Battery Module Combiner (NB) LED is OFF, the combiner may be energized with power from the Power Conversion System (inverter-charger / MPPT controller).
- Verify the terminal voltage with a voltmeter before handling any components in the Energy Storage System.

Failure to follow these instructions may result in death or serious injury.

The Battery Module Combiner's At-a-glance LED indicates the state of the Battery Modules.

Table 6-1, At-a-glance LED States

| LED | Description |
|--------------|--|
| No LED light | None of the Battery Modules are switched ON. |
| Solid Green | One or more connected Battery Modules are switched ON. |

7. PREPARING THE BATTERY MODULE COMBINER (NB) FOR INSTALLATION

7.1 Tools

- Insulated tools sized to match nuts, bolts, and cables in use
- RMS type Voltmeter
- Post cleaner and wire brush
- Personal protective equipment

7.2 Terminal Connections

⚠ CAUTION

ELECTRICAL AND FIRE HAZARD

Failure to torque up to specification may increase resistance and lower voltage, leading to burnout of the terminals. Torquing up over the specification may damage the equipment.

Failure to follow these instructions may result in injury or equipment damage.

All cable lugs must be in direct contact with the busbar terminal deck and secured to the correct terminal point using the specified torque.

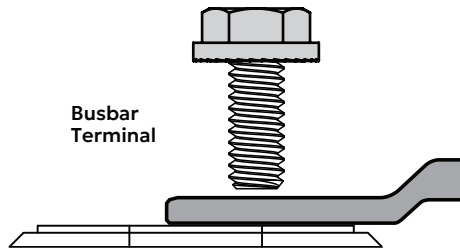

Figure 5. Busbar Terminal Installation

Connections to terminals must meet the following requirements:

1. **Connect the cable to the terminal.** All cable lugs must be in direct contact with the busbar terminal deck. Do not put washers between the terminal deck and the cable lug.
2. **Use the Proper Torque.** Use a torque wrench to adjust terminal hardware with the proper torque, 8 to 10 Nm (5.9 to 7.4 ft/lbs) for M6 Battery Module terminals on the busbar and 21.4 Nm (15.8 ft-lb) for M8 Power Conversion Equipment terminals on the busbars. Periodically check to ensure that torque values meet specifications.

7.3 Removing Unused Battery Module Cables

⚠ CAUTION

ELECTRICAL AND FIRE HAZARD

Failure to torque all cable terminals to the correct specification may increase resistance and lower voltage, leading to burnout of the terminal connections. Torque all M6 Battery Module cable terminals to 8 to 10 Nm (5.9 to 7.4 ft-lb). Exceeding 10 Nm (7.4 ft-lb) of torque will damage the terminal.

Failure to follow these instructions may result in injury or equipment damage.

The AES RACKMOUNT Battery Module Combiner (No Breaker) is pre-wired to be connected to six Battery Modules. The Battery Module Combiner (NB) has six fuses to protect each pair of pre-installed Battery Module cables. There are two open fuse positions (unpopulated) available for either another two Battery Modules or DC loads.

If your system will use fewer than six Battery Modules, remove the pairs of cables not being used before installation and mounting of the Battery Module Combiner (NB).

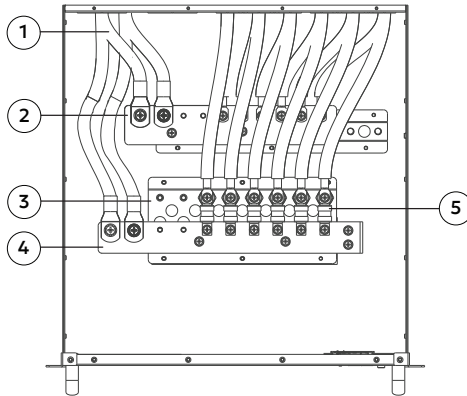

Figure 6. Battery Module Combiner (NB) with the top removed

| Item | Description |
|------|--|
| 1 | DC input/output lines of Power Conversion Equipment (not provided). |
| 2 | Negative Busbar 10 Connection Points: 6 Battery Module M6, 2 DC Loads M6, 2 Power Conversion Equipment M8 |
| 3 | Isolated Fuse Mounting Plate with 8 Connection Points: 6 positive standoffs for Battery Module M6 (Fuse - Populated), 2 standoffs for DC Loads M6 (Fuse - Unpopulated) |
| 4 | Positive Busbar 10 Connection Points: 6 Battery Module M6 (Fuse - Populated), 2 DC Loads M6 (Fuse - Unpopulated), 2 Power Conversion Equipment M8 (Fuse - Unpopulated) |
| 5 | DC Fuses are attached to the Positive Busbar inline with the Battery Module/ DC Loads: 6 Battery Module M6 (Fuse - Populated), 2 DC Loads M6 (Fuse - Unpopulated) |

1. Disconnect the Battery Module Combiner (NB) from all sources of energy and ensure the Battery Module Combiner (NB) is de-energized.
2. Use a Phillips screwdriver to remove the 20 screws along the borders of the top and the side edges and remove the top cover. Do not remove the handles or flanges if you are only removing the top cover.
3. Identify the Positive (+) and Negative (-) busbars hosting the Battery Module cables and the positive and negative 3 AWG (26.5 mm²) gauge wires connected to the busbars.
4. Unscrew the bolt from a 3 AWG (26.5 mm²) Battery Module cable connected to the negative busbar and remove the negative cable.
5. Unscrew the bolt from the 3 AWG (26.5 mm²) Battery Module cable connected to the positive terminal with the fuse, and remove the positive cable.
6. Return the M6 bolts to their positions using the following torque: 8 to 10 Nm (5.9 to 7.4 ft-lb).
 - Note that it is not necessary to remove the unused fuse.
7. Repeat to reduce the number of positive and negative Battery Module cables to match the number of Battery Modules in the system.
8. Install the cables for the power conversion system. Refer to [7.4 Installing Cables for the Power Conversion System](#).

7.4 Installing Cables for the Power Conversion System

CAUTION

ELECTRICAL AND FIRE HAZARD

- Failure to torque the Power Conversion terminals to the specification may increase resistance and lower voltage, leading to burnout of the terminal connections.
 - Torque the M8 bolts on the negative and positive terminals to 21.4 Nm (15.8 ft-lb). Exceeding 21.4 Nm (15.8 ft-lb) of torque could damage the terminal connection.

Failure to follow these instructions may result in injury or equipment damage.

The AES RACKMOUNT Battery Module Combiner (No Breaker) is supplied with two M8 terminals on the negative busbar and two M8 terminals on the positive busbar for attaching two Power Conversion Equipment (inverter-charger/ MPPT controller) cable sets (Power Conversion cables are not included with the Battery Module Combiner).

Refer to the Power Conversion Equipment manual for cable sizing, torque specifications, and connection information.

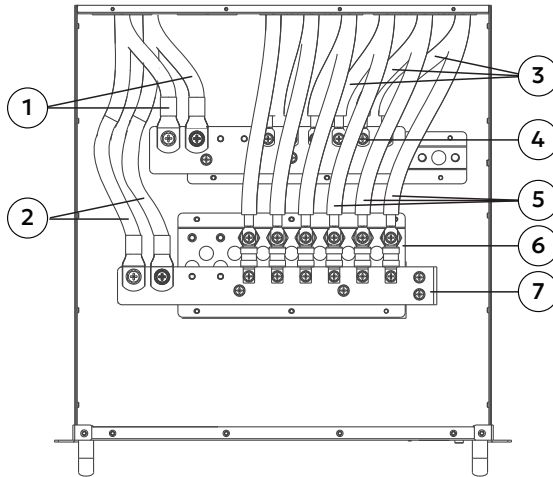

Figure 7. Battery Module Combiner (NB) Cable Connections

| Item | Description |
|------|--|
| 1 | Two negative cable lines to Power Conversion Equipment (inverter-charger / MPPT controller) (Power Conversion cables are not included with the Battery Module Combiner) |
| 2 | Two positive cable lines to Power Conversion Equipment (inverter-charger/ MPPT controller) (Power Conversion Equipment cables are not included with the Battery Module Combiner) |
| 3 | Negative cables to Battery Modules |
| 4 | Negative busbar M6 terminal points for Battery Modules and for Power Conversion Equipment |
| 5 | Positive cables to Battery Modules |
| 6 | Positive busbar M6 terminal points for Battery Modules and DC fuses |
| 7 | Positive busbar M6 terminal points for DC fuses and M8 terminal points for Power Conversion Equipment |

1. Disconnect the Battery Module Combiner (NB) from all sources of energy and ensure the Battery Module Combiner (NB) is de-energized.
2. Use a Phillips screwdriver to remove the twenty M3 and M4 screws along the borders of the top and the side edges and remove the top cover.
3. Using power cables that meet the requirements of the Power Conversion Equipment (inverter-charger / MPPT controller), pass the cables through the large knockouts and attach the red positive (+) cables to the M8 terminals on the busbar (see #2 in the diagram), then the black negative (-) cables to the negative M8 terminals on the busbar (see #1 in the diagram).
 - Apply 21.4 Nm (15.8 ft-lb) of torque to tighten M8 terminal connections.

4. Secure all positive and negative battery cable M6 terminals using a torque of 8 to 10 Nm (5.9 to 7.4 ft/lbs).
5. Depending on the local authority having jurisdiction, you may be required to add external disconnects (i.e. fuses) in the positive pole, or both negative and positive poles.
The fuses should be as close as possible to the Battery Module Combiner (NB).
Applicable codes may limit how far the protection can be from the Battery Modules.
6. Replace the cover and screw down using the following torque values.
 - M3 screws: 1.9 Nm (1.4 ft-lb)
 - M4 screws: 4.4 Nm (3.25 ft-lb)

8. MOUNTING THE BATTERY MODULE COMBINER (NB)

The Battery Module Combiner (NB) is designed for indoor installations in a vertical stack with up to six AES RACKMOUNT Battery Modules in either a standard nineteen-inch four-post metal rack or the Quick Stack Rack. The Battery Module Combiner (NB) is supplied with cables for connection to six Battery Modules.

The Battery Module Combiner (NB) must be supported and secured using heat-resistant non-flammable materials.

The following instructions are for installing the Battery Module Combiner (NB) with Battery Modules in a standard nineteen-inch four-post metal rack (not included with the Battery Module Combiner or Battery Modules).

For information on installing in a Quick Stack Rack, see [AES RACKMOUNT Quick Stack Rack Manual](#) (805-0056).

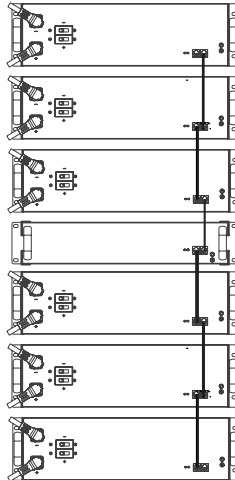

Figure 8. Six batteries with Battery Module Combiner (NB)

NOTICE

- Do not install the Battery Module Combiner (NB) with the faceplate down.
- Support and secure the Battery Module Combiner (NB) using heat-resistant non-flammable materials.
- The Battery Module Combiner (NB) is rated IP20 for indoor installations.

NOTE

1U of rack space equals 44.45 mm (1.75 inch).

8.1 Location

Install the Battery Module Combiner (NB) in a location that meets the following requirements:

1. **Do not install in direct sunlight.** Avoid installing the Battery Module Combiner (NB) and Battery Modules in an area with direct sunlight.
2. **Moderate temperatures.** Ambient temperatures should be between 0°C and 40°C (32°F and 104°F). Ambient temperatures of 15°C to 20°C (59°F to 68°F) are ideal for extending LiFePO₄ battery life.
3. **Ventilated.** Do not install in zero-clearance compartments. Maintain at least 1U (44.45 mm, 1.75 inch) space around the Battery Module Combiner (NB) and Battery Modules for airflow and heat dissipation.
4. **Proper orientation.** Do not install the Battery Module Combiner (NB) or Battery Modules face-down.
5. **Install indoors.** Install the Battery Module Combiner (NB) and Battery Modules indoors.

8.2 Spacing

When installed in a standard nineteen-inch four-post metal rack, provide 1U (44.45 mm, 1.75 inch) spacing on all sides of the Battery Module Combiner (NB) to allow for airflow and heat dissipation.

Alternatively, if the Battery Module Combiner (NB) is installed on a shelf, maintain at least 1U of clearance space above and on both sides of the Battery Module Combiner (NB) as well as under the shelf to allow for airflow and heat dissipation.

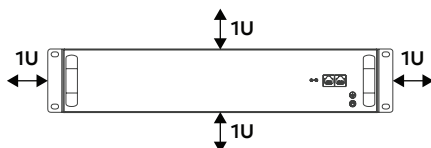

Figure 9. Spacing around the Battery Module Combiner (NB)

8.3 Support

Support the weight of the Battery Module Combiner (NB) by installing metal L-shaped rails (not included with Battery Module Combiner) between the front and back posts on both the left and right sides. The flanges attached to the front face of the Battery Module Combiner (NB) have holes for attaching the Battery Module Combiner (NB) to the front post of the rack system using M6 screws and cage nuts.

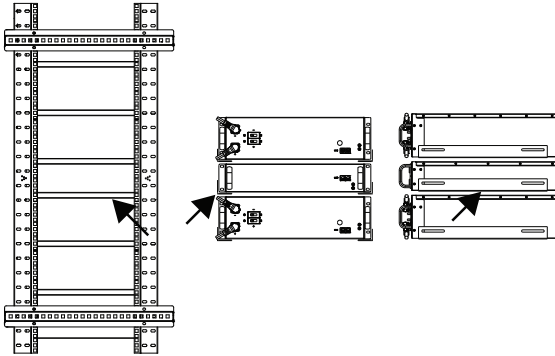

Figure 10. Rack with L-shaped rails



Figure 11. Mounting Points

9. CONNECTING THE BATTERY MODULE COMBINER (NB)

The instructions below describe how to connect the Battery Module Combiner (NB) once mounted.

9.1 Grounding the Battery Module Combiner (NB)

Ground the Battery Module Combiner (NB) and all Battery Modules to the rack chassis and ground the chassis to earth.

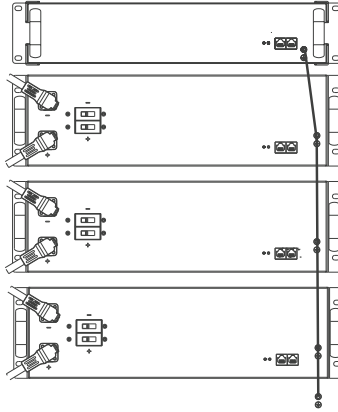

Figure 12. Grounding the Battery Module Combiner (NB)

1. Ground the Battery Module Combiner (NB) and all Battery Modules to the rack chassis using a #6 gauge or larger diameter wire.
2. Ground the rack chassis to earth with a #4 gauge or larger diameter wire.

NOTE

Refer to the applicable code and check with the authority having jurisdiction to confirm local requirements.

9.2 Connecting the Battery Modules

Amphenol SurLok Plus connectors attached to the DC Battery Cables mate with the battery terminal receiving pins on the faceplate of the AES RACKMOUNT Battery Module.

- Positive (+) Red: Amphenol SurLok Plus C10-730186-200
- Negative (-) Black: Amphenol SurLok Plus C10-730186-100

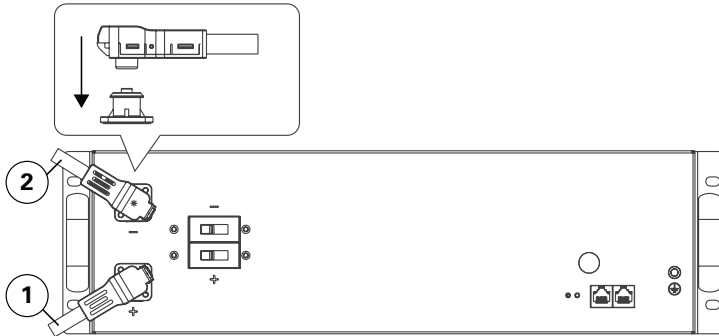

Figure 13. Connect Amphenol SurLok Plus connectors to the Battery Module

1. Attach all the red, positive (+) cables from the Battery Module Combiner (NB) to the red, positive (+) terminals on the Battery Modules using the red Amphenol SurLok Plus connectors.
 - Push until you hear a click to engage the mating lock on the Amphenol SurLok Plus connector.
2. Attach all the black, negative (-) cables from the Battery Module Combiner (NB) to the negative (-) black terminals on the Battery Modules using the black Amphenol SurLok Plus connectors.
 - Push until you hear a click to engage the mating lock on the Amphenol SurLok Plus connector.

NOTICE

Failure to securely engage the mating lock on a terminal connection will increase resistance and lower voltage, leading to burnout of the terminals.

NOTE

Without exception, a product experiencing terminal burnout will void the warranty.

9.3 Connecting the DC Power Conversion Cables

After the DC Battery Module cables are connected, connect the DC Power Conversion cables (previously installed to the Battery Module Combiner) to the Power Conversion Equipment (inverter-charger / MPPT controller).

Refer to the manual of the inverter-charger / MPPT controller for the appropriate cable sizing, torque specifications, and connection information.

9.4 Networking the Battery Modules to the Battery Combiner Module

Using a CAT6 cable, connect the last Battery Module in the Battery Modules network with the Battery Module Combiner (NB) using one of the LYNK Ports on the faceplate.

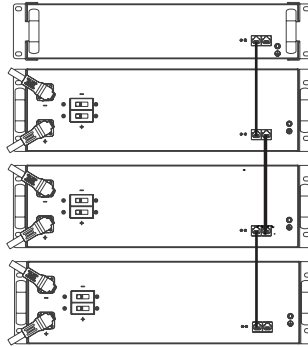

Figure 14. Networking the Battery Modules with the Battery Combiner Module

10. CLOSED-LOOP COMMUNICATION WITH POWER CONVERSION EQUIPMENT

For closed-loop communication with the Power Conversion Equipment (inverter-charger / MPPT controller), network the Battery Module Combiner (NB) with a LYNK II Gateway. Connect the LYNK II Gateway to the Power Conversion System (refer to the 805-0033 [LYNK II Installation and Operation Manual](#)).

For instructions on the setup of closed-loop communication with Power Conversion Equipment, refer to the LYNK II application note specific to the brand of Power Conversion Equipment in use.

11. ROUTINE INSPECTION

Periodically inspect the battery system:

1. Ensure that all DC cables are secure and fasteners are tight.
2. Ensure all networking cables and connectors are secure and tight.
3. Ensure that the installation location is clean and free from debris.
4. Inspect for cracks in the Battery Modules.
5. Replace any damaged Battery Modules.
6. Replace any damaged cables.

12. REPLACING A FUSE

CAUTION

ELECTRIC SHOCK

- Do not touch the energized surfaces of any electrical component in the battery system.
- Before servicing the Battery Module Combiner (NB), follow all procedures to fully de-energize the battery system and use safe handling procedures when handling the battery.

Failure to follow these instructions may result in injury.

Table 12-1 AES RACKMOUNT Battery Module Combiner (No Breaker) - Battery Module Cable Fuse Specifications

| Service Part | AES RACKMOUNT Battery Module Combiner (No Breaker) 950-0049-NB |
|----------------------|---|
| DC Fuse | CHNBEL LET-200-100 A, Fast 20 kAIC |
| Fuse Terminal Torque | 8 to 10 Nm (5.9 to 7.4 ft/lbs) DO NOT EXCEED 10 Nm (7.4 ft/lbs) |

This task should be performed by qualified personnel:

- Use only insulated tools
- Wear personal protective equipment
- The battery system must be de-energized
- Battery cables must be disconnected
- Battery terminals must be protected from short-circuiting and touch

Refer to sections [7.2 Terminal Connections](#), [7.3 Removing Unused Battery Module Cables](#), [7.4 Installing Cables for the Power Conversion System](#), and [9.2 Connecting the Battery Modules](#).

Ensure that the Power Conversion system is de-energized and all loads are disconnected from the Battery Module Combiner (NB).

1. De-energize the Power Conversion Equipment.
2. Open any disconnects leading to the Battery Module Combiner (NB).
3. Switch all Battery Modules to OFF.
4. Disconnect all the Amphenol SurLok Plus connectors from all the Battery modules to isolate the Battery Module Combiner (NB).
5. Protect the Battery Module terminals from short-circuiting and touch by covering them with terminal covers or electrically rated tape.
6. Disconnect the Power Conversion cables attached to the Battery Module Combiner (NB).
7. Access the top of the Battery Module Combiner (NB) and remove the cover.
8. Using a Digital Multimeter set to continuity check, identify the blown fuse.
9. Remove the bolt holding the fuse from the standoff first, and then remove the bolt from the busbar.

10. Replace the fuse with a new fuse paying strict attention to orientation and the fuse ratings in [Table 12-1 AES RACKMOUNT Battery Module Combiner \(No Breaker\) - Battery Module Cable Fuse Specifications](#).
11. Attach the bolts to hold the new fuse on the busbar first, and then the standoff, using a torque of 8 to 10 Nm (5.9 to 7.4 ft/lbs). DO NOT EXCEED 10 Nm (7.4 ft-lb).
12. Reinstall the Battery Module Combiner (NB) into the system by reversing the operations from steps 7 to 1.

13. OPTIONAL ACCESSORIES

The following components are available for use with the AES RACKMOUNT Battery Module Combiner (No Breaker).

Table 13-1, Accessories

| Accessory | Part Number |
|--|--------------------------|
| AES RACKMOUNT Battery Module | 48-48-5120 900-0062 |
| AES RACKMOUNT Battery Module - Heated | 48-48-5120-H 900-0067 |
| LYNK II Communication Gateway | 950-0025 |
| AES RACKMOUNT Quick Stack Rack | 950-0050 |
| AES RACKMOUNT Battery Terminal Connector Set | 950-0054 |

14. RELATED INFORMATION

Find information about Discover Energy Systems at discoverenergysys.com.