

HELIOS ESS Quick Start Guide



This document is not intended as a replacement for the manual.



Electrical Specifications	Description
Nominal Voltage	51.2 V
Recommended Voltage Range	48 - 55.2 V
Energy	16,080 Wh
Nominal Capacity	314 Ah
Charge Bulk Voltage - Bulk Vdc	55.2 – 56.8 V
Charge Absorption Voltage - U1 MAX	55.2 – 56.8 V
Charge Float Voltage - U2	53.6 V
Charge Termination Current	5 A
Low Voltage Disconnect Recommended	48.0 V
BMS Under Voltage Protection	43.2 V
Max. Continuous Charge Current	200 A
Max. Continuous Discharge Current	200 A
Peak Discharge Current (15 seconds)	300 A RMS
Breaker	200 A breaker
Self Discharge Current (operation)	≤ 25 mA
Self Discharge Current (battery OFF)	≤ 4 mA

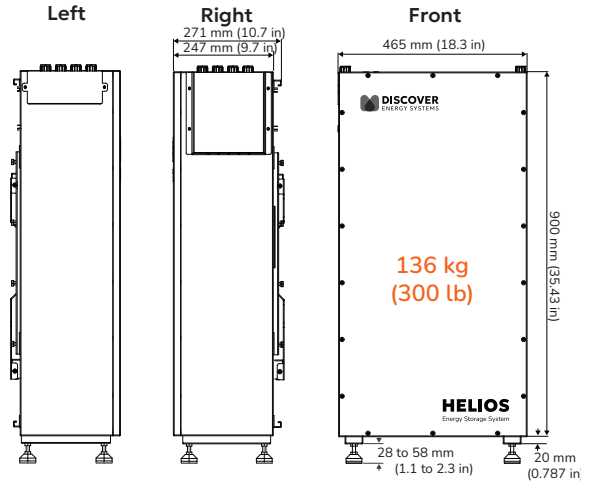

INSTALLATION

Test the Battery; update firmware.



1. After unboxing the battery, close the battery breaker and turn ON the battery.
2. With a multimeter, verify the voltage at the battery terminals.
3. Ensure the battery is running the latest firmware version. The update can be performed using the USB-C port.

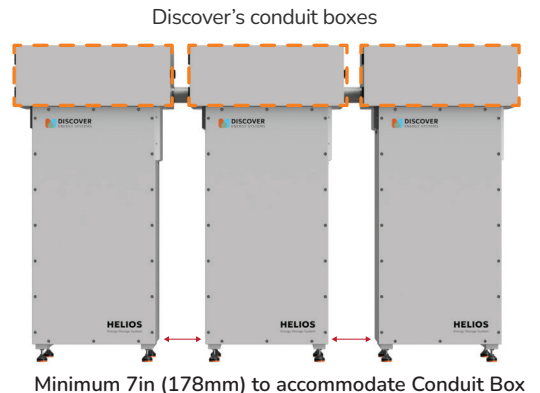
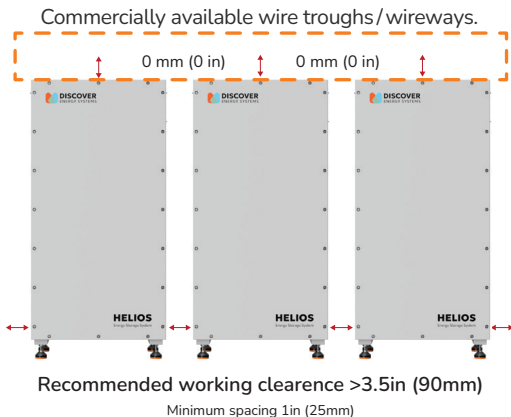

MOUNTING

Mount the bracket/battery directly on the wall at an elevated height, or floor-supported.

Note: The battery's feet are adjustable and can be used for leveling and support.

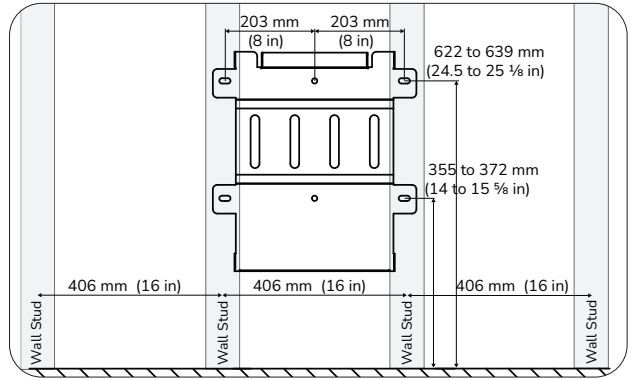

WIRING

Each battery includes a 200 A breaker. Additional over current protection may be required between the battery bank and load; many DC loads (inverters) include integrated over-current protection.

CABLES. One, two or three batteries

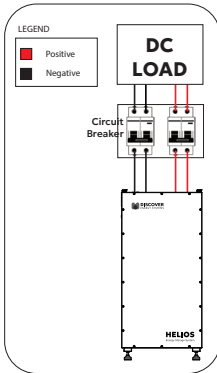

Example: One battery

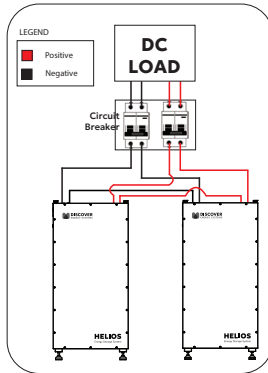

Example: Two batteries

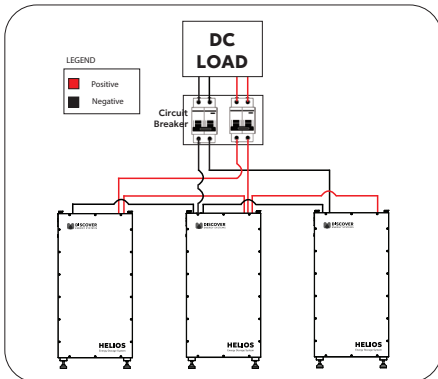

Example: Three batteries

BUSBAR. More than three batteries

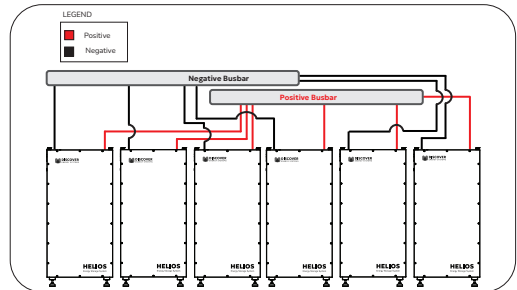

Example: Six groups of 1 (UL9540: 52-48-16000_1)

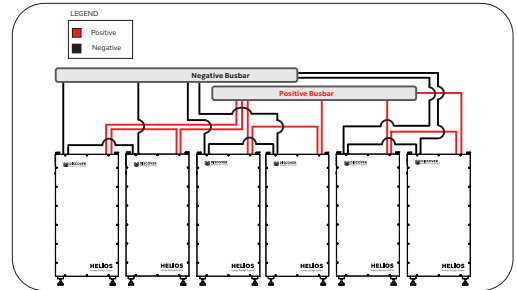

Example: Three groups of 2 (UL9540: 52-48-16000_2)

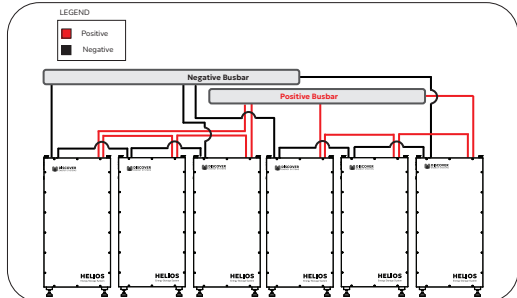

Example: Two groups of 3 (UL9540: 52-48-16000_3)

GROUNDING

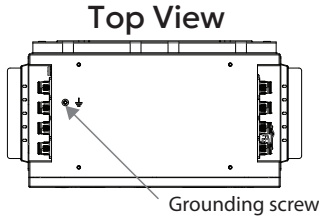

Connect AWG 6 grounding wires from battery to battery to the inverter's grounding port.

**Note that there are 4 grounding screws in the back of Discover Energy conduit boxes.*

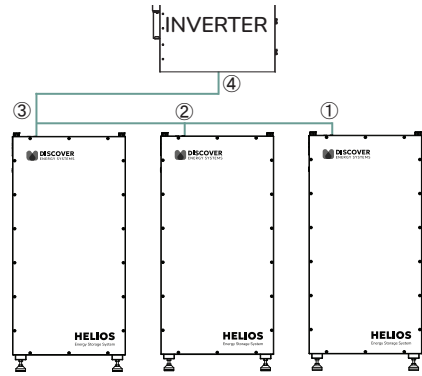

COMMUNICATION

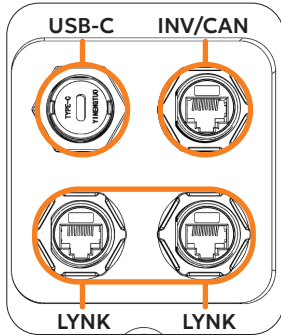

- Use CAT5e or higher cables for LYNK II and CAN communication.
- **USB-C Port** for firmware update, diagnostics and technical support. Use LYNK ACCESS software.
- **CAN Port** for native closed-loop communication with compatible inverters. See manual for full list.
- **LYNK Ports** for communication between batteries, and connecting to the LYNK II Gateway. **If using LYNK II, ensure it is running the latest firmware version (2.5 or later).**

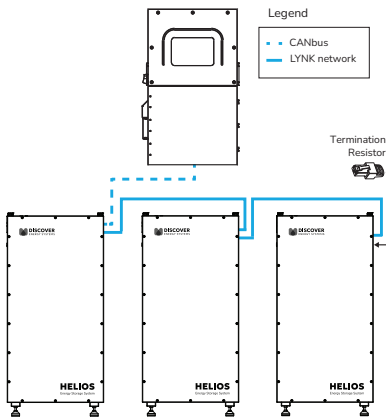

COMMUNICATION WITHOUT LYNK II GATEWAY

When setting up closed-loop communication without the LYNK II Gateway, connect a termination resistor on the last battery in the LYNK network.

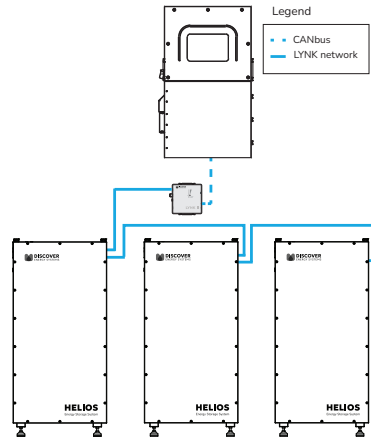

COMMUNICATION WITH LYNK II GATEWAY

If your system uses a LYNK II Gateway, you can use LYNK Cloud for remote monitoring.



LEARN MORE ABOUT LYNK CLOUD

START UP PROCEDURE (WITH BUILT-IN PRE-CHARGE)

1. Verify the polarity of battery cables and ensure cables are securely connected.
2. Ensure all batteries are turned OFF.
3. Close battery breakers on all the batteries (ON).
4. Close all DC load breakers, including the inverter's battery breaker.
5. Press each battery ON/OFF switch to initiate pre-charge and activation.

When the battery LED is ON solid, the battery begins supplying power.



If the LED flashes, press the ON/OFF switch again to repeat initiating pre-charge.

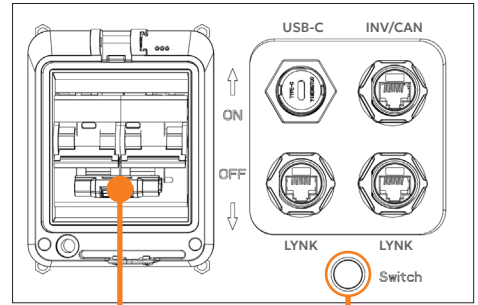

Battery Breaker

ON/OFF Switch (LED)

POWER DOWN PROCEDURE

1. Turn off the DC loads or inverter.
2. Press the ON/OFF switch to turn the battery off.
3. Open the breakers on all batteries (OFF).

TROUBLESHOOTING

LED is flashing after turning the battery ON with load connected.

- **Plausible fault. Failed to pre-charge.**
 - Repeat START UP PROCEDURE. Large capacitance DC loads may require multiple pre-charge attempts.
 - If the fault persists, use LYNK Access PC Software to diagnose the issue. (Scan the QR code for more information)



Closed-loop communication is not working.

- **Plausible faults. The battery is not communicating with the inverter.**
 - Inverter not configured correctly. Check inverter settings.
 - Communication cable may be damaged or incorrectly pinned. Inspect all communication cables. When using the LYNK II Gateway, confirm that the jumpers are configured for your inverter model. Refer to LYNK II Gateway Manual (scan QR code).
 - Sol-Ark inverter not registering communication. Reboot the MCU by pressing and holding the ESC button for 5 seconds.

COM2 Port RJ45 Pin Assignment

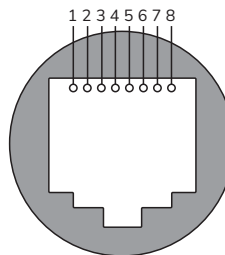

Pin #	Function
1	(Do not use)
2	(Do not use)
3	(Do not use)
4	CAN High
5	CAN Low
6	CAN Ground
7	(Do not use)
8	(Do not use)



Multi-battery system data inaccurate in closed-loop.

- **Plausible fault. Inter-battery communication issue.**
 - Check inter-battery communication. Ensure all communication cables are securely connected to COM3/4.
 - Verify that ONE termination resistor is installed on the first OR last battery. If using a LYNK II Gateway, no termination resistor is required. (Device is internally terminated)



Register your HELIOS battery on the same day it is installed.

Retain full warranty coverage and enjoy faster support when you need it.

Just scan the QR code. It only takes a few minutes and guarantees your system is fully documented and protected.